



Product Specifications

Bedford Handrail Systems

Disclaimer

BEDFORD REINFORCED PLASTICS INC. disclaims liability for any personal injury, property or other damages of any nature whatsoever, whether special, indirect, consequential or compensatory, directly or indirectly resulting from the publication, use of, or reliance on BEDFORD REINFORCED PLASTICS INC. documents. BEDFORD REINFORCED PLASTICS INC. also makes no guaranty or warranty as to the accuracy or completeness of any information published herein. Anyone using this document should rely on his or her own independent judgment or, as appropriate, seek the advice of a competent professional in determining the exercise of reasonable care in any given circumstances.

Product Specification

BRP Handrail Systems

Scope

This specification covers the details about the design criteria, product description and installation details of BRP handrail systems.

Design Criteria

BRP handrail systems are designed to exceed the minimum load requirements of handrail systems as per OSHA 1910.23.

BRP Handrail Systems

BRP fabricates two types of handrail systems, 1. Heavy Duty Handrail System, and 2. Standard Duty Handrail System, depending on the size of the members used for vertical and horizontal rails and the type of connectors utilized.

Heavy Duty Handrail System:

This handrail assembly utilizes pultruded 2" x ¼" square tube as vertical and horizontal rails connected using a 1½" x ¼" solid FRP bar as a connector. The rails and connectors are mechanically fastened using a ¼" dia. series 300 SS spring pin.

Standard Duty Handrail System:

This handrail assembly utilizes pultruded 2" x ⅝" square tube as horizontal rails and pultruded 1¾" x ¼" square tube as vertical rails with 2" x ⅝" square tube as a sleeve up to the mid-rail for added strength. The vertical rails are passed through the horizontal and connected using a ¼" nylon pop rivet.

Product Description

Horizontal and vertical members used for handrail assemblies are made with the pultrusion process using fiberglass

reinforcement and resin systems necessary to meet the design requirements and minimum properties given in Table 1.

Glass Reinforcements: Pultruded structural shapes used for handrail systems shall have the fiber reinforcement in the form of continuous rovings and continuous strand mat for adequate mechanical and physical properties and surface veil for UV protection and corrosion resistance.

Resin Systems: Resin systems used in BRP handrail systems provide superior corrosion resistance and are available in FR Iso-Polyester and Vinylester resin systems with additives for superior fire resistance, UV protection and pigments. BRP handrail systems are typically pigmented yellow and can match other colors if needed.

Table 1. Minimum Properties

Property	ASTM	Value
Tensile Strength, psi	D 638	30000
Tensile Modulus, psi	D 638	2.5 x10 ⁶
Flexural Strength, psi	D 790	30000
Flexural Modulus, psi	D 790	1.8 x10 ⁶
Short Beam Shear, psi	D 2344	4500
Full Section Modulus, psi	N/A	2.8 x10 ⁶
Density, lb/in ³	D 792	0.062-0.07
Flame Spread	E 84	25 or less

Installation Methods

Typical BRP handrail systems are fabricated for side mount installation using a 1½" x ¼" solid FRP bar as a bottom plug to avoid crushing of vertical posts during installation. Typical side mount handrail assemblies are secured in place using ½" diameter anchor bolts or studs. BRP handrail systems can also be installed using other attachment methods such as base mounts as per the shop drawings approved by the design engineer.

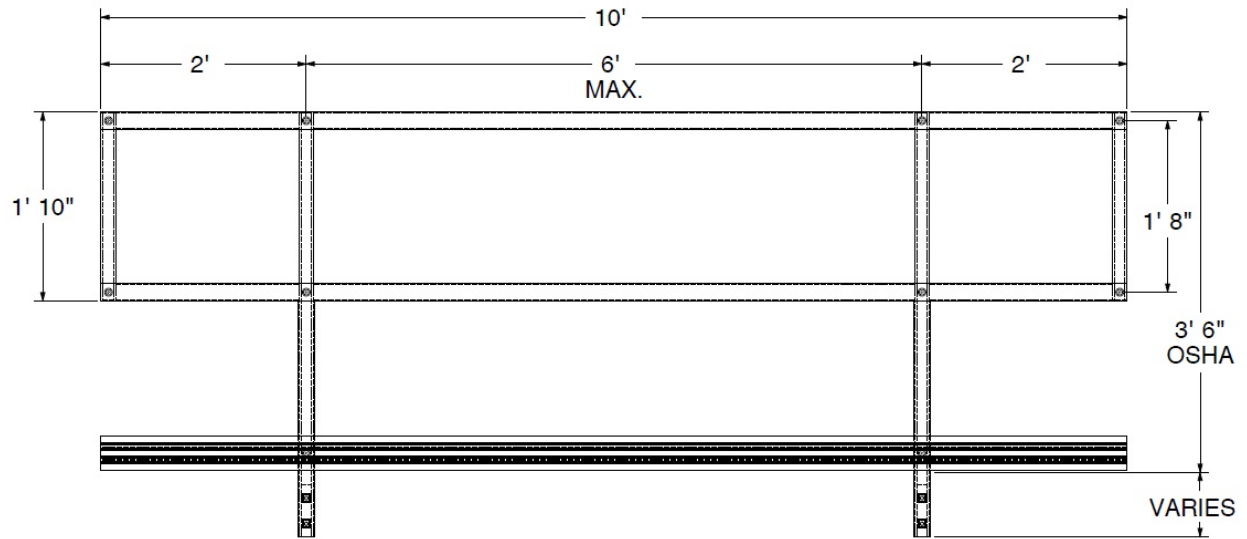

BRP Standard Duty Handrail System with Returns

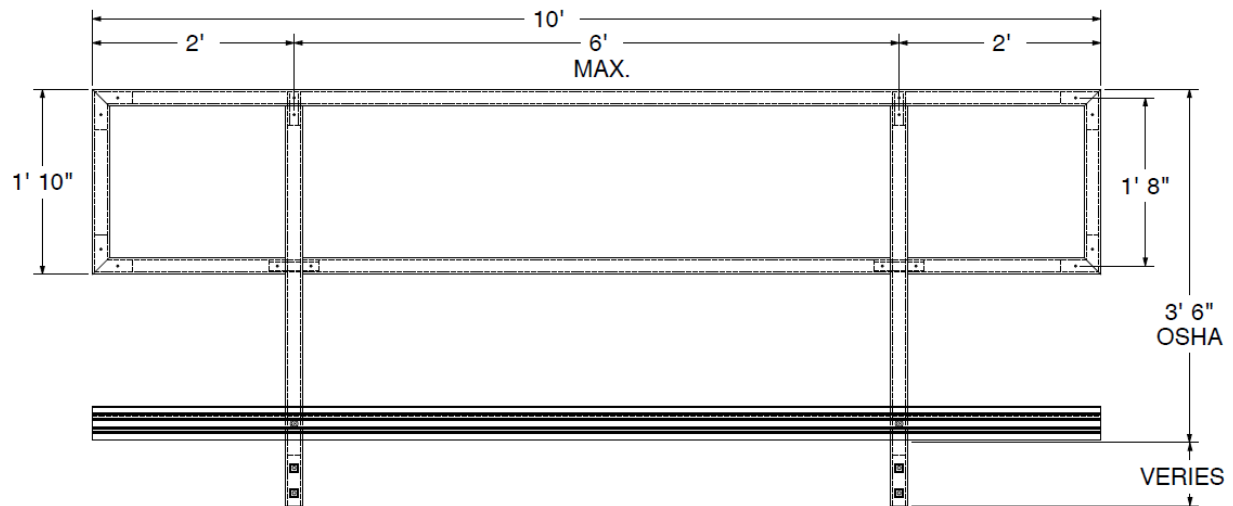

BRP Heavy Duty Handrail System with Returns

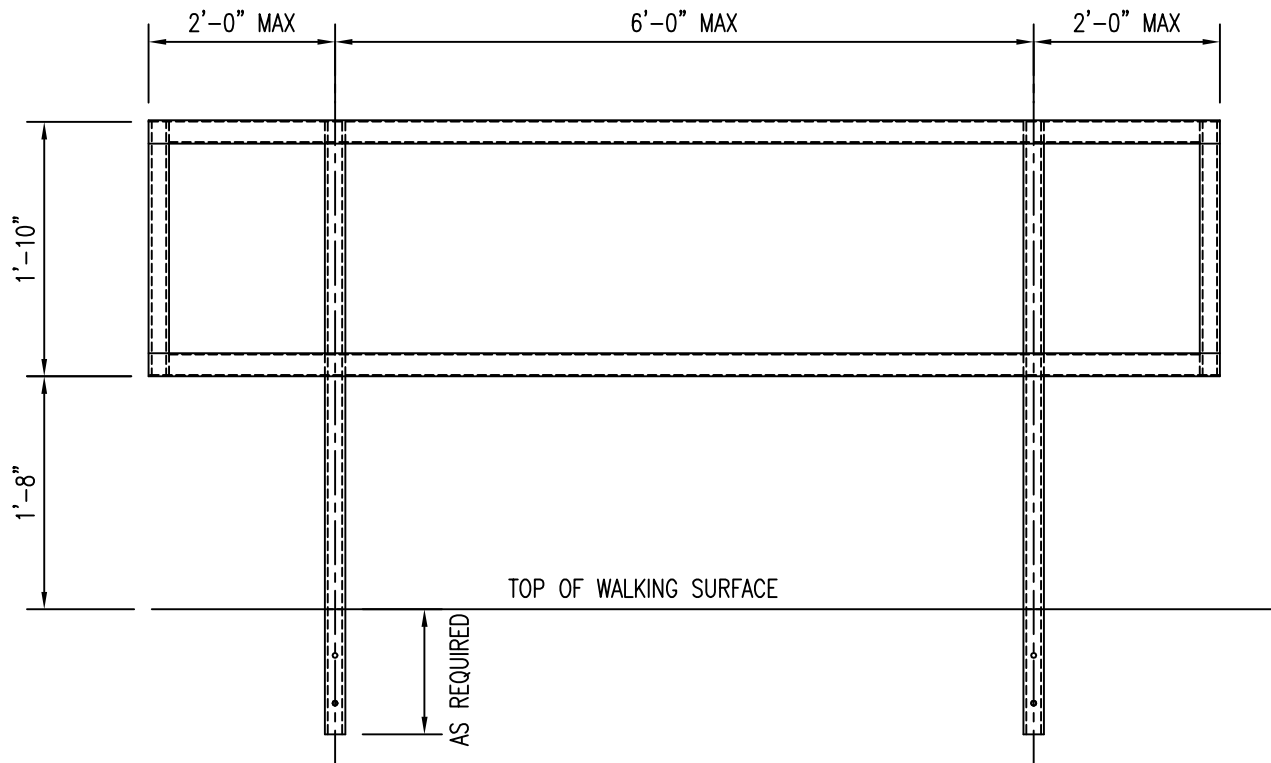

STANDARD AND HEAVY DUTY HANDRAIL REQUIREMENTS



264 REYNOLDSDALE ROAD
BEDFORD, PENNSYLVANIA 15522

PHONE: 814-623-8125 WEB SITE: www.bedfordreinforced.com
FAX: 814-623-6032 EMAIL: sales@bedfordreinforced.com

TITLE:

STANDARD
AND HEAVY DUTY
HANDRAIL
REQUIREMENTS

HANDRAIL TYPE:
FR RESIN:
VE RESIN:

HANDRAIL COLOR:
YELLOW:
OTHER: _____
(IF OTHER PLEASE NOTE COLOR)

SCALE: N.T.S.

DATE: 5-15-14

DRAWN BY: BB

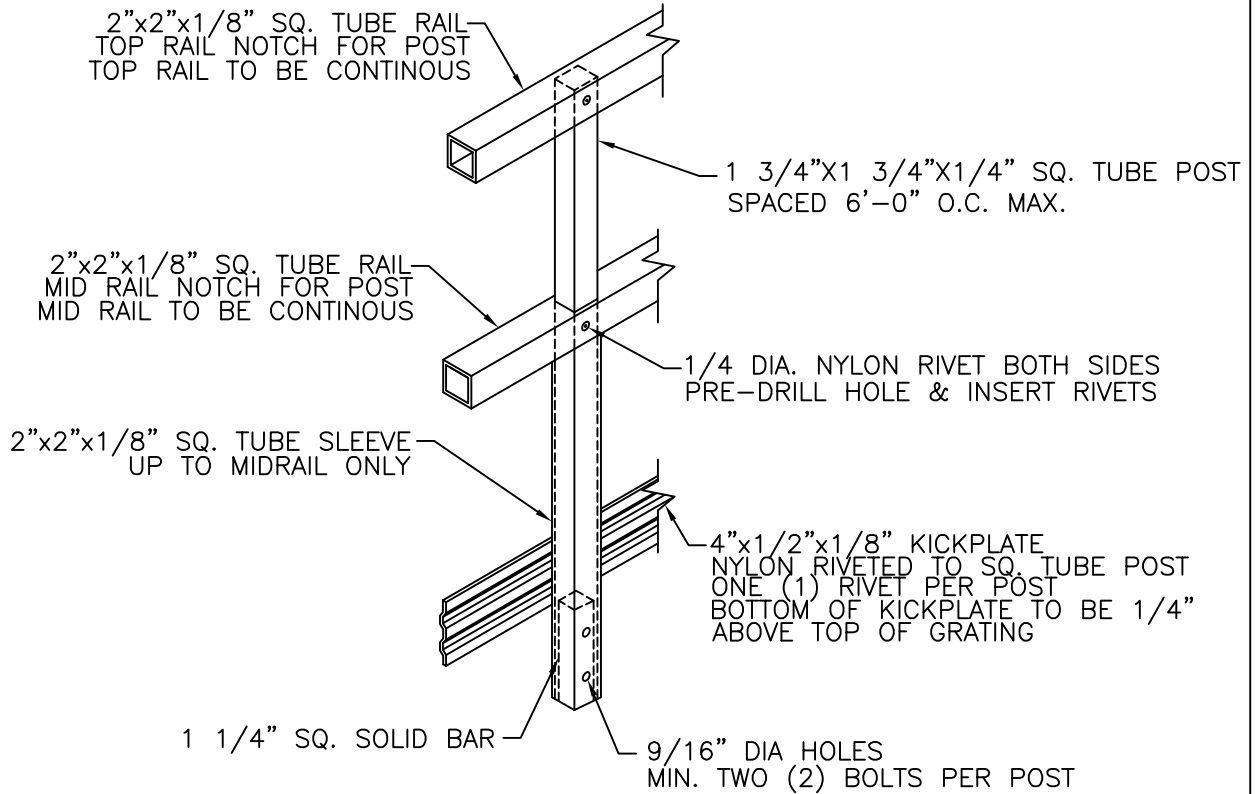

STANDARD DUTY HANDRAIL



264 REYNOLDSDALE ROAD
BEDFORD, PENNSYLVANIA 15522

PHONE: 814-623-8125 WEB SITE: www.bedfordreinforced.com
FAX: 814-623-6032 EMAIL: sales@bedfordreinforced.com

TITLE:

STANDARD DUTY
HANDRAIL

HANDRAIL TYPE:
FR RESIN:
VE RESIN:

HANDRAIL COLOR:
YELLOW:
OTHER: _____
(IF OTHER PLEASE NOTE COLOR)

SCALE: N.T.S.

DATE: 5-15-14

DRAWN BY: BB

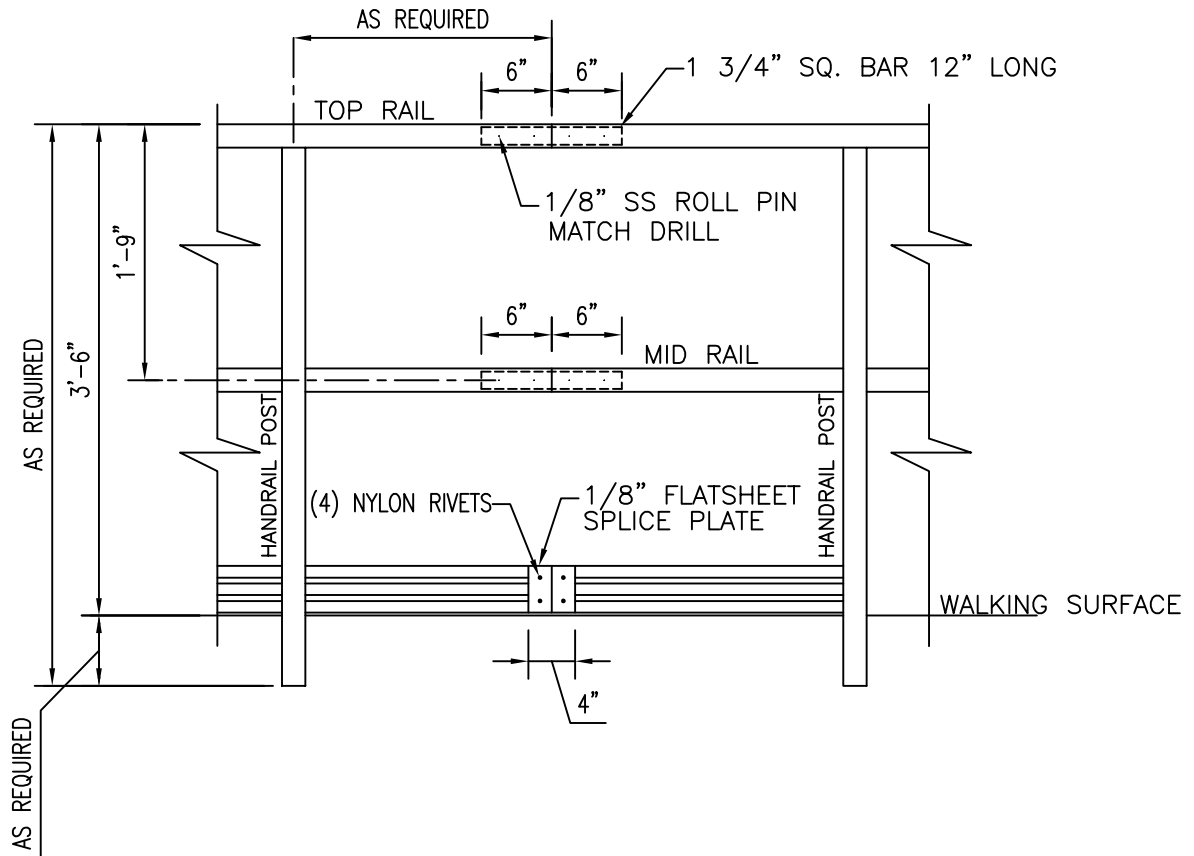

STANDARD DUTY HANDRAIL SPLICE DETAIL



264 REYNOLDSDALE ROAD
BEDFORD, PENNSYLVANIA 15522

PHONE: 814-623-8125 WEB SITE: www.bedfordreinforced.com
FAX: 814-623-6032 EMAIL: sales@bedfordreinforced.com

TITLE:

STANDARD DUTY HANDRAIL
SPLICE DETAIL

HANDRAIL TYPE:
FR RESIN:
VE RESIN:

HANDRAIL COLOR:
YELLOW:
OTHER: _____
(IF OTHER PLEASE NOTE COLOR)

SCALE: N.T.S.

DATE: 5-15-14

DRAWN BY: BB

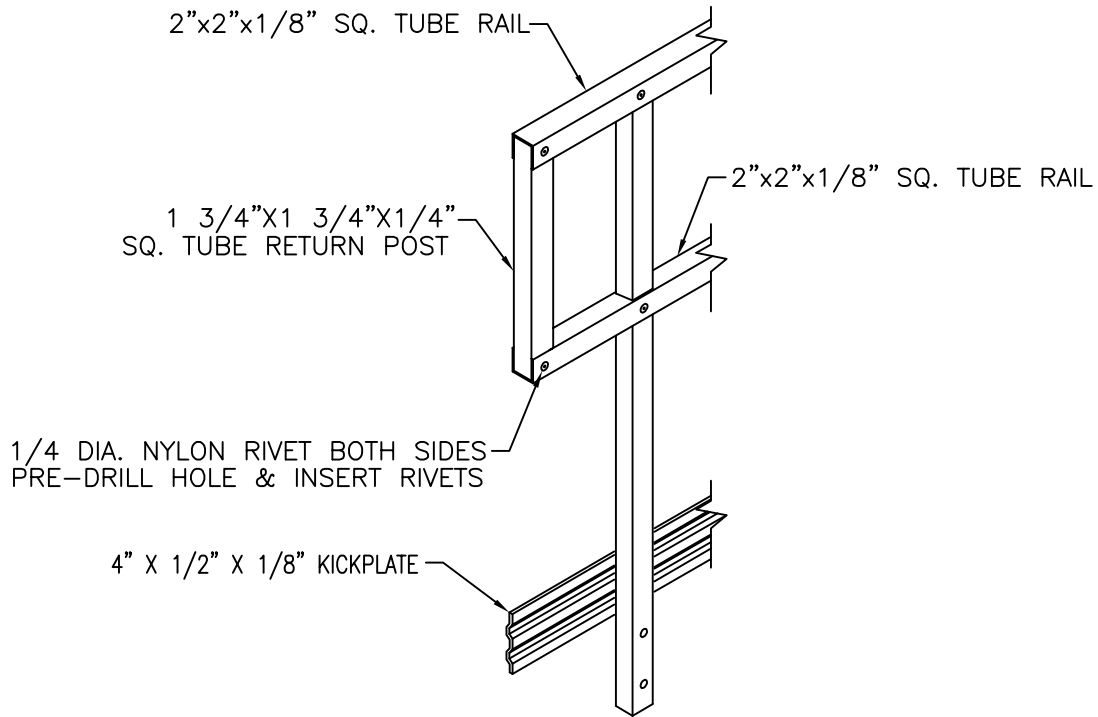

STANDARD DUTY HANDRAIL RETURN POST DETAIL



264 REYNOLDSDALE ROAD
BEDFORD, PENNSYLVANIA 15522

PHONE: 814-623-8125 WEB SITE: www.bedfordreinforced.com
FAX: 814-623-6032 EMAIL: sales@bedfordreinforced.com

TITLE:

STANDARD DUTY HANDRAIL
RETURN POST DETAIL

HANDRAIL TYPE:
FR RESIN:
VE RESIN:

HANDRAIL COLOR:
YELLOW:
OTHER: _____
(IF OTHER PLEASE NOTE COLOR)

SCALE: N.T.S.

DATE: 5-15-14

DRAWN BY: BB

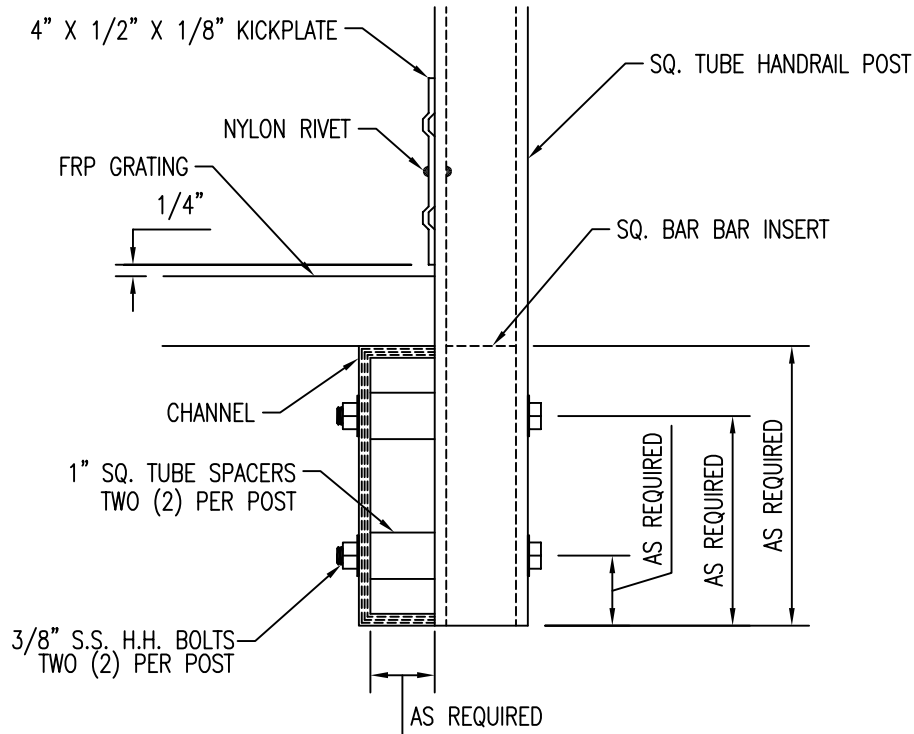

HANDRAIL TO CHANNEL CONNECTIONS



264 REYNOLDSDALE ROAD
BEDFORD, PENNSYLVANIA 15522

PHONE: 814-623-8125 WEB SITE: www.bedfordreinforced.com
FAX: 814-623-6032 EMAIL: sales@bedfordreinforced.com

TITLE:

STANDARD
AND HEAVY DUTY
HANDRAIL
TO CHANNEL CONNECTIONS

HANDRAIL TYPE:
FR RESIN:
VE RESIN:

HANDRAIL COLOR:
YELLOW:
OTHER: _____
(IF OTHER PLEASE NOTE COLOR)

SCALE: N.T.S.

DATE: 5-15-14

DRAWN BY: BB

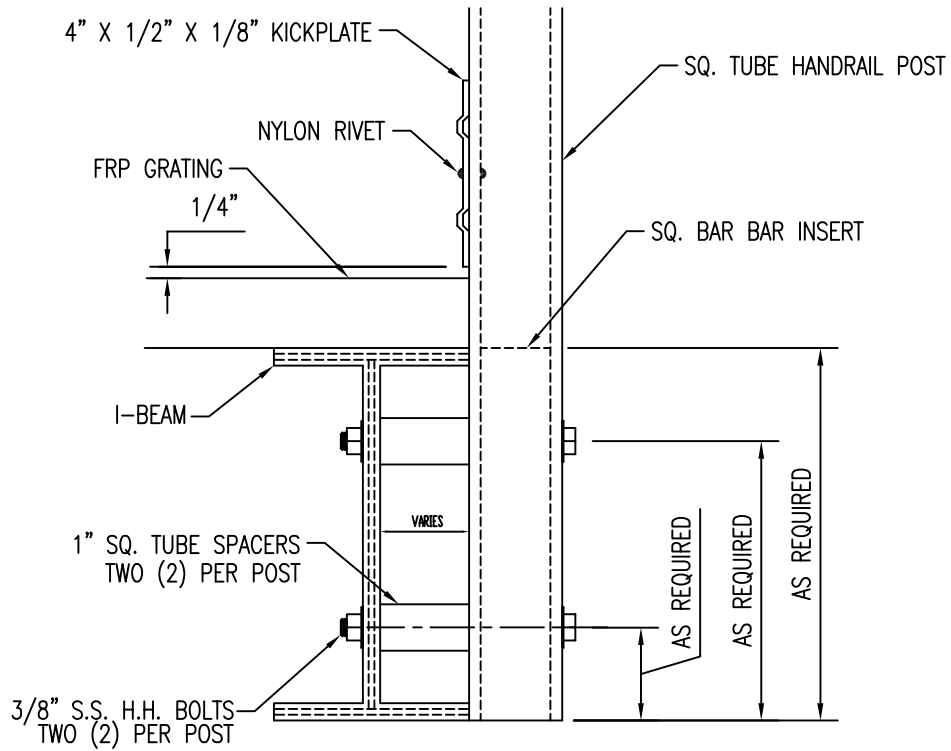

HANDRAIL TO I-BEAM CONNECTIONS



264 REYNOLDSDALE ROAD
BEDFORD, PENNSYLVANIA 15522

PHONE: 814-623-8125 WEB SITE: www.bedfordreinforced.com
FAX: 814-623-6032 EMAIL: sales@bedfordreinforced.com

TITLE:

STANDARD
AND HEAVY DUTY
HANDRAIL
TO I-BEAM
CONNECTIONS

HANDRAIL TYPE:
FR RESIN:
VE RESIN:

HANDRAIL COLOR:
YELLOW:
OTHER: _____
(IF OTHER PLEASE NOTE COLOR)

SCALE: N.T.S.

DATE: 5-15-14

DRAWN BY: BB

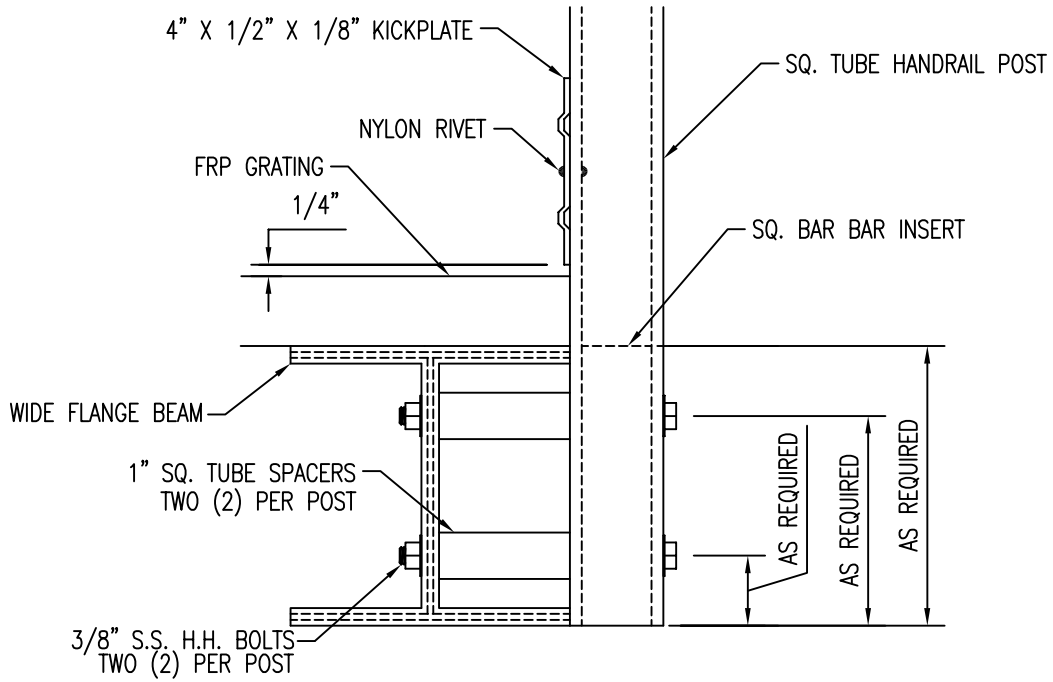

HANDRAIL TO WIDE FLANGE BEAM CONNECTIONS



264 REYNOLDSDALE ROAD
BEDFORD, PENNSYLVANIA 15522

PHONE: 814-623-8125 WEB SITE: www.bedfordreinforced.com
FAX: 814-623-6032 EMAIL: sales@bedfordreinforced.com

TITLE:

STANDARD
AND HEAVY DUTY
HANDRAIL
TO WIDE FLANGE BEAM
CONNECTIONS

HANDRAIL TYPE:
FR RESIN:
VE RESIN:

HANDRAIL COLOR:
YELLOW:
OTHER: _____
(IF OTHER PLEASE NOTE COLOR)

SCALE: N.T.S.

DATE: 5-15-14

DRAWN BY: BB

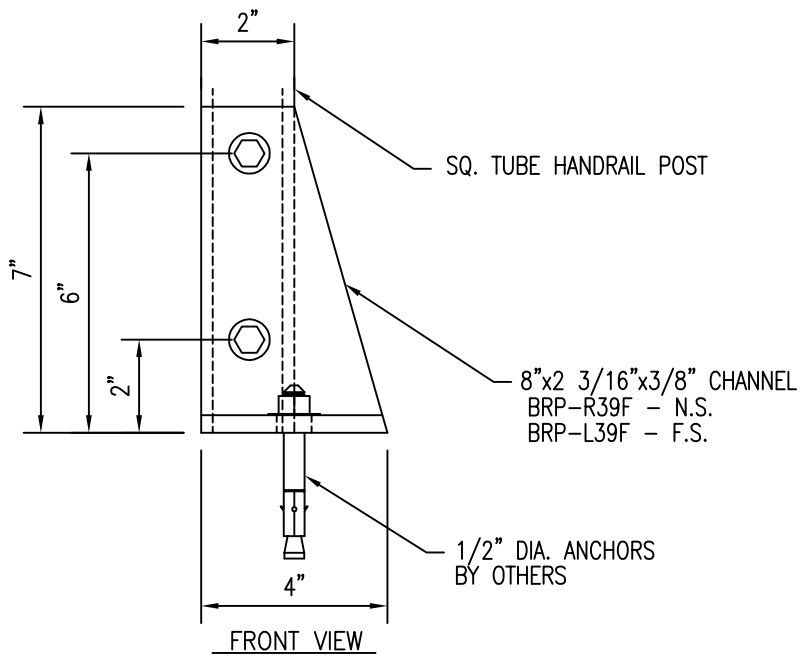
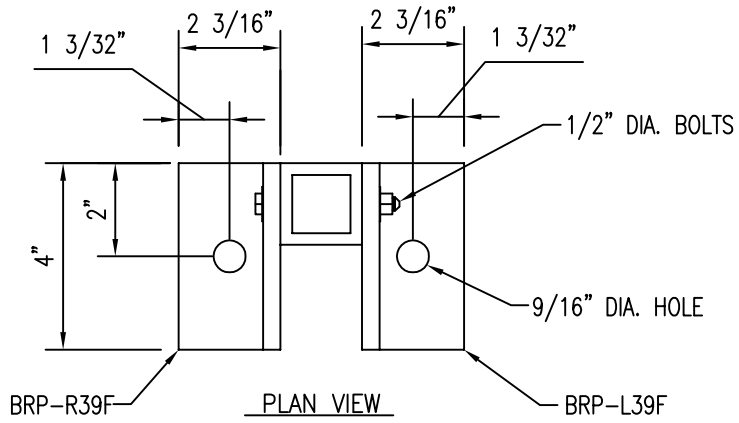

BASEPLATE MOUNTED HANDRAIL



264 REYNOLDSDALE ROAD
BEDFORD, PENNSYLVANIA 15522

PHONE: 814-623-8125 WEB SITE: www.bedfordreinforced.com
FAX: 814-623-6032 EMAIL: sales@bedfordreinforced.com

TITLE:

STANDARD
AND HEAVY DUTY
HANDRAIL
BASE PLATE MOUNT

HANDRAIL TYPE:
FR RESIN: DK. GRAY
VE RESIN: BEIGE

SCALE: N.T.S.

DATE: 5-15-14

DRAWN BY: BB

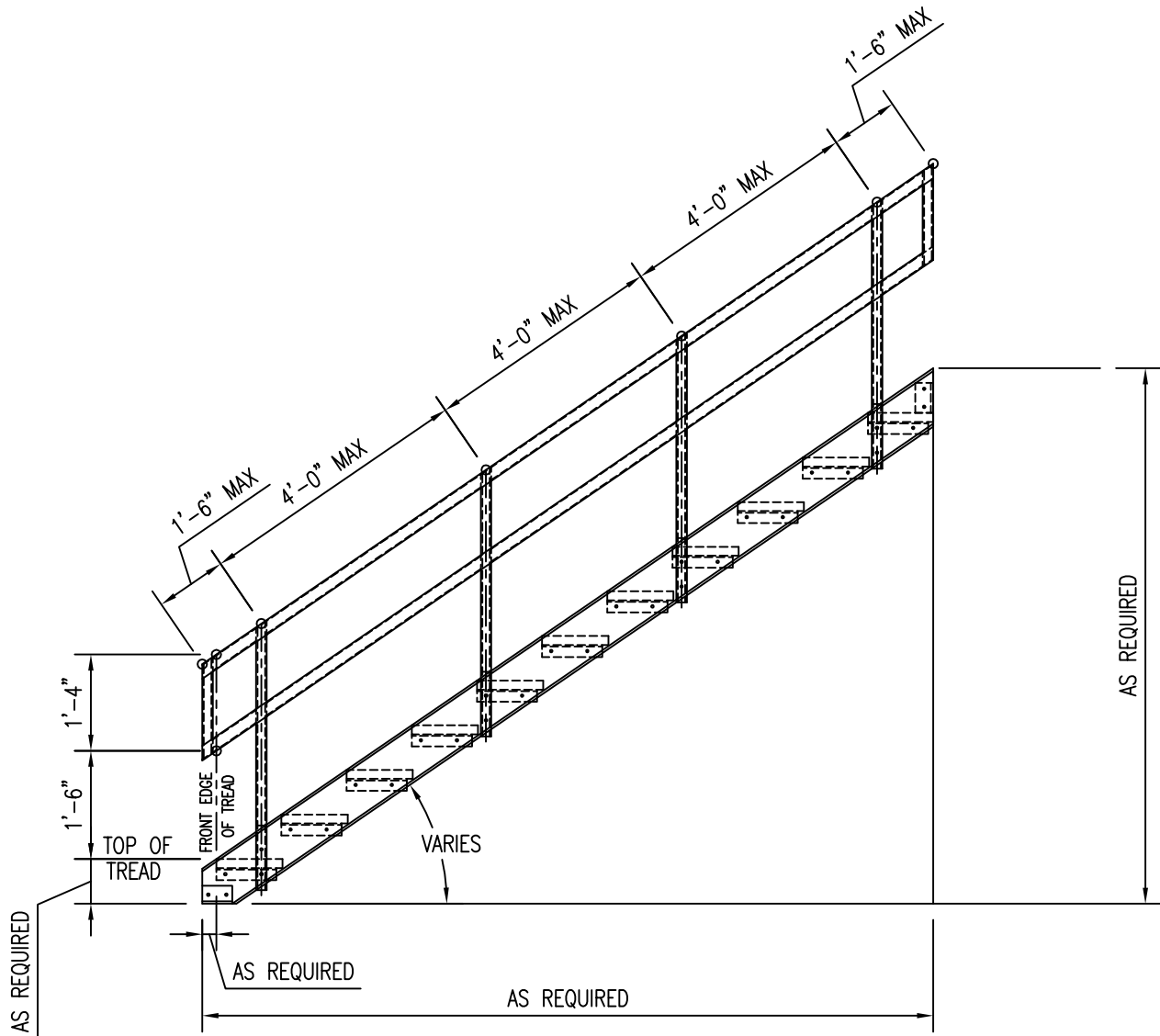

STANDARD AND HEAVY DUTY STAIR HANDRAIL (OSHA SPEC)



264 REYNOLDSDALE ROAD
BEDFORD, PENNSYLVANIA 15522

PHONE: 814-623-8125 WEB SITE: www.bedfordreinforced.com
FAX: 814-623-6032 EMAIL: sales@bedfordreinforced.com

TITLE:

STANDARD
AND HEAVY DUTY
STAIR HANDRAIL
OSHA SPEC

HANDRAIL TYPE:
FR RESIN:
VE RESIN:

HANDRAIL COLOR:
YELLOW:
OTHER: _____
(IF OTHER PLEASE NOTE COLOR)

SCALE: N.T.S.

DATE: 5-15-14

DRAWN BY: BB

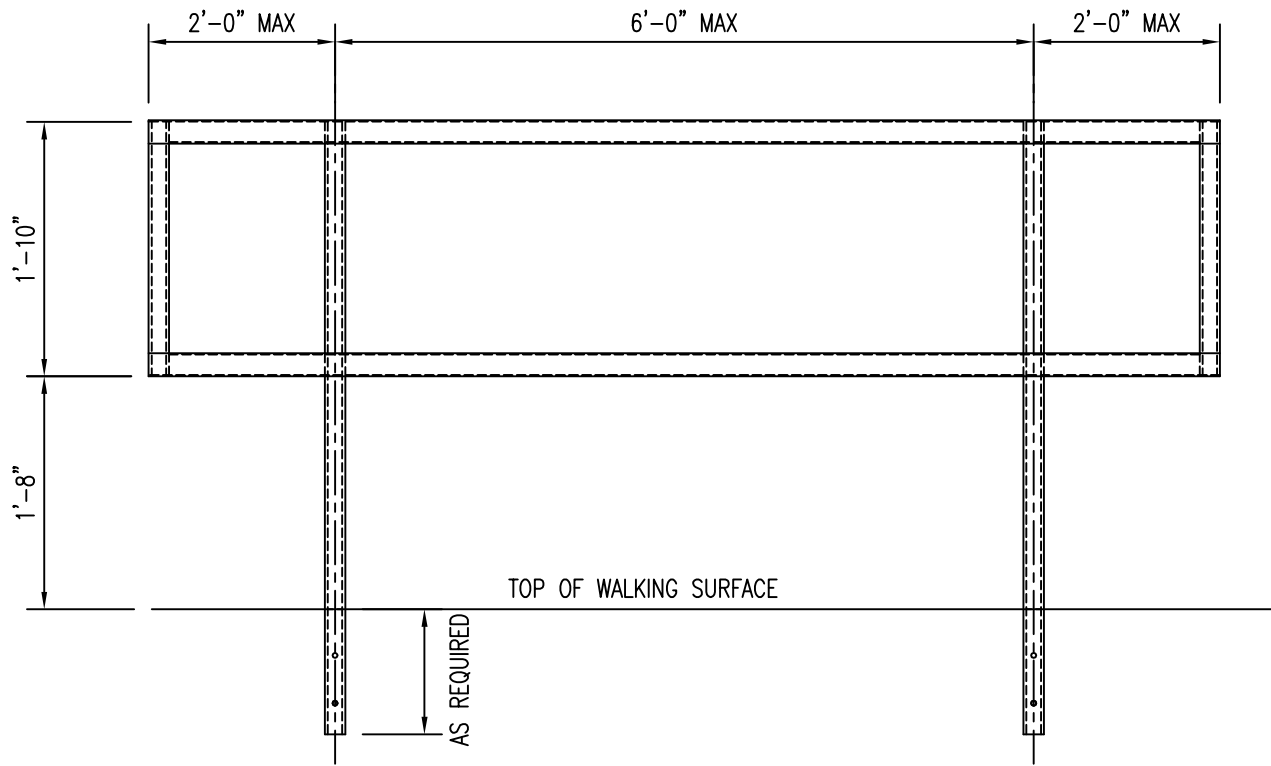

STANDARD AND HEAVY DUTY HANDRAIL REQUIREMENTS



264 REYNOLDSDALE ROAD
BEDFORD, PENNSYLVANIA 15522

PHONE: 814-623-8125 WEB SITE: www.bedfordreinforced.com
FAX: 814-623-6032 EMAIL: sales@bedfordreinforced.com

TITLE:

STANDARD
AND HEAVY DUTY
HANDRAIL
REQUIREMENTS

HANDRAIL TYPE:
FR RESIN:
VE RESIN:

HANDRAIL COLOR:
YELLOW:
OTHER: _____
(IF OTHER PLEASE NOTE COLOR)

SCALE: N.T.S.

DATE: 5-15-14

DRAWN BY: BB

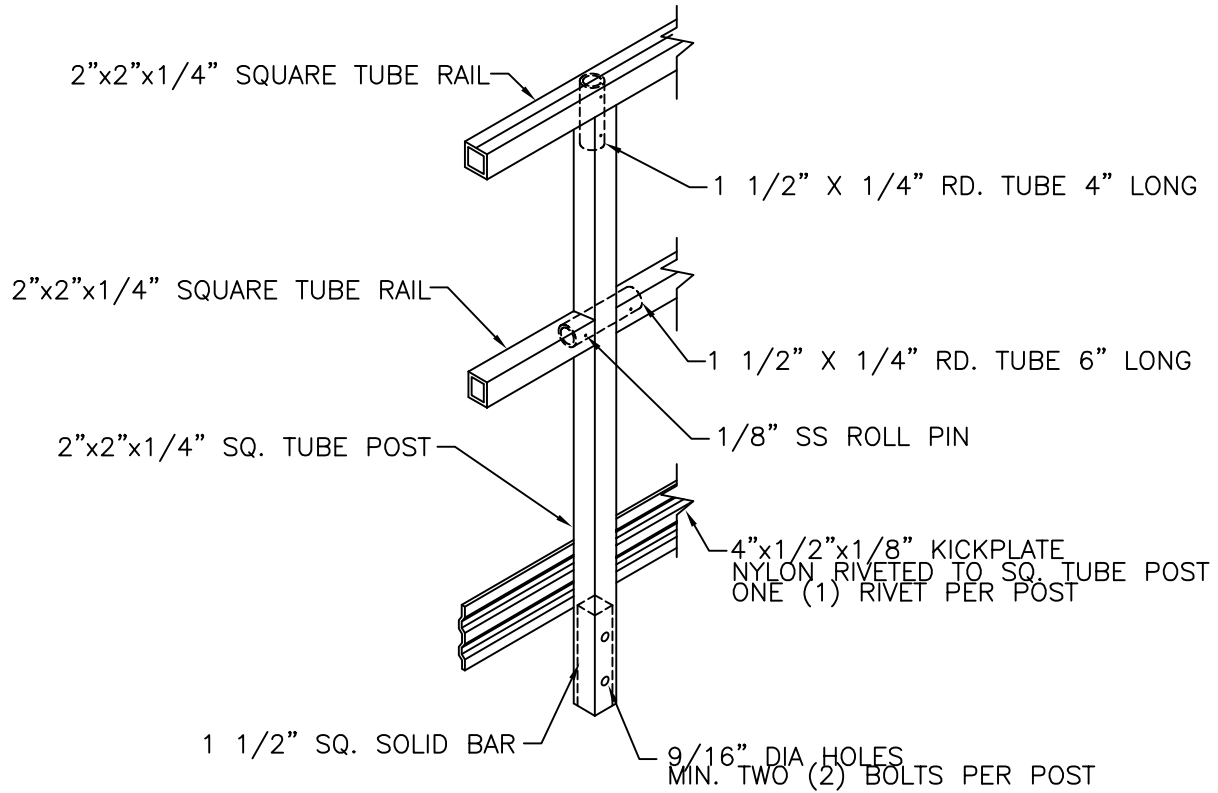

HEAVY DUTY HANDRAIL



264 REYNOLDSDALE ROAD
BEDFORD, PENNSYLVANIA 15522

PHONE: 814-623-8125 WEB SITE: www.bedfordreinforced.com
FAX: 814-623-6032 EMAIL: sales@bedfordreinforced.com

TITLE:

HEAVY DUTY
HANDRAIL

HANDRAIL TYPE:
FR RESIN:
VE RESIN:

HANDRAIL COLOR:
YELLOW:
OTHER: _____
(IF OTHER PLEASE NOTE COLOR)

SCALE: N.T.S.

DATE: 5-15-14

DRAWN BY: BB

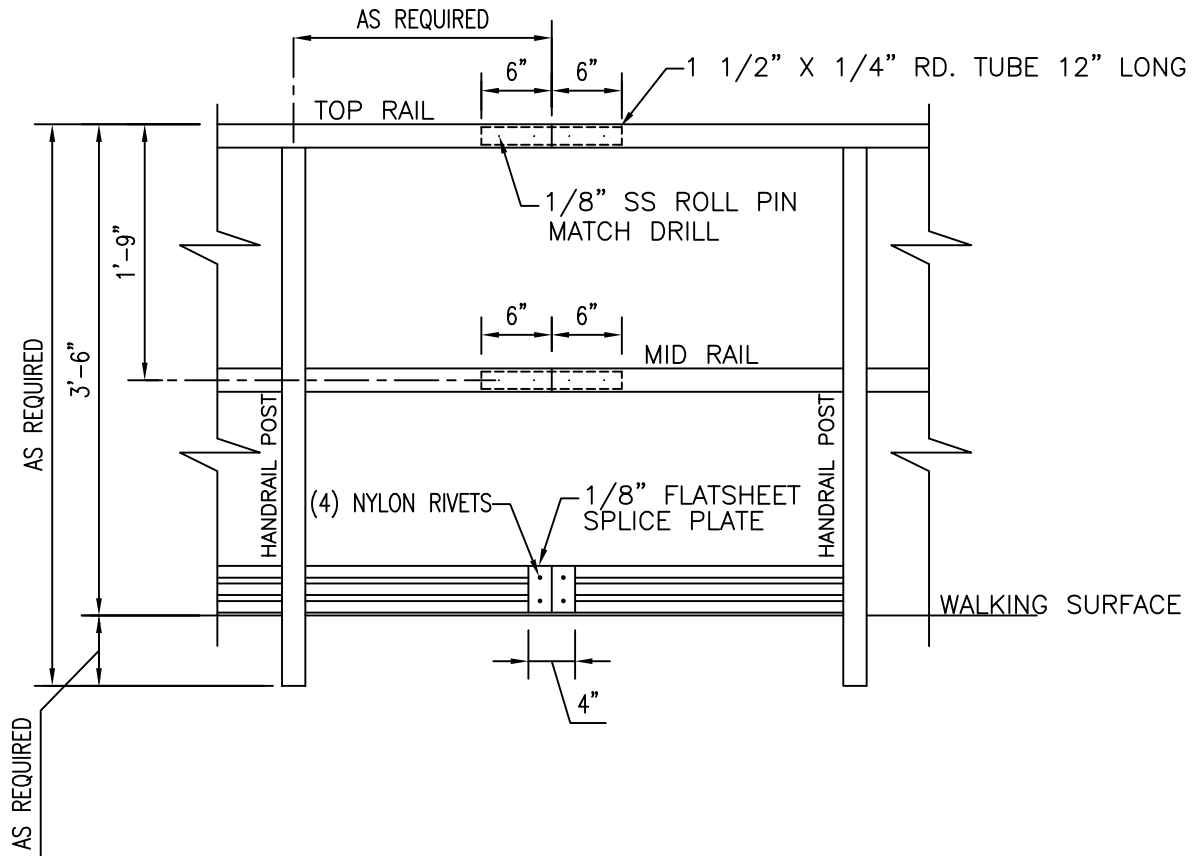

HEAVY DUTY HANDRAIL SPLICE DETAIL



264 REYNOLDSDALE ROAD
BEDFORD, PENNSYLVANIA 15522

PHONE: 814-623-8125 WEB SITE: www.bedfordreinforced.com
FAX: 814-623-6032 EMAIL: sales@bedfordreinforced.com

TITLE:

HEAVY DUTY HANDRAIL
SPLICE DETAIL

HANDRAIL TYPE:
FR RESIN:
VE RESIN:

HANDRAIL COLOR:
YELLOW:
OTHER: _____
(IF OTHER PLEASE NOTE COLOR)

SCALE: N.T.S.

DATE: 5-15-14

DRAWN BY: BB

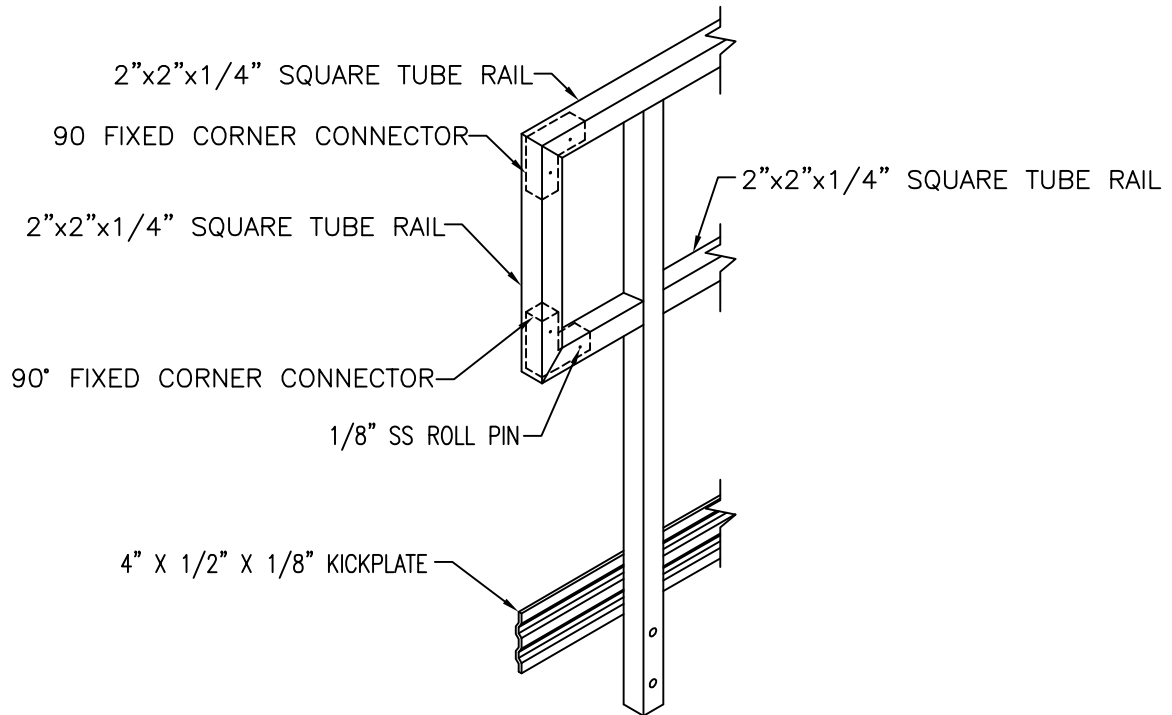

HEAVY DUTY HANDRAIL RETURN POST DETAIL



264 REYNOLDSDALE ROAD
BEDFORD, PENNSYLVANIA 15522

PHONE: 814-623-8125 WEB SITE: www.bedfordreinforced.com
FAX: 814-623-6032 EMAIL: sales@bedfordreinforced.com

TITLE:

HEAVY DUTY HANDRAIL
RETURN POST DETAIL

HANDRAIL TYPE:
FR RESIN:
VE RESIN:

HANDRAIL COLOR:
YELLOW:
OTHER: _____
(IF OTHER PLEASE NOTE COLOR)

SCALE: N.T.S.

DATE: 5-15-14

DRAWN BY: BB

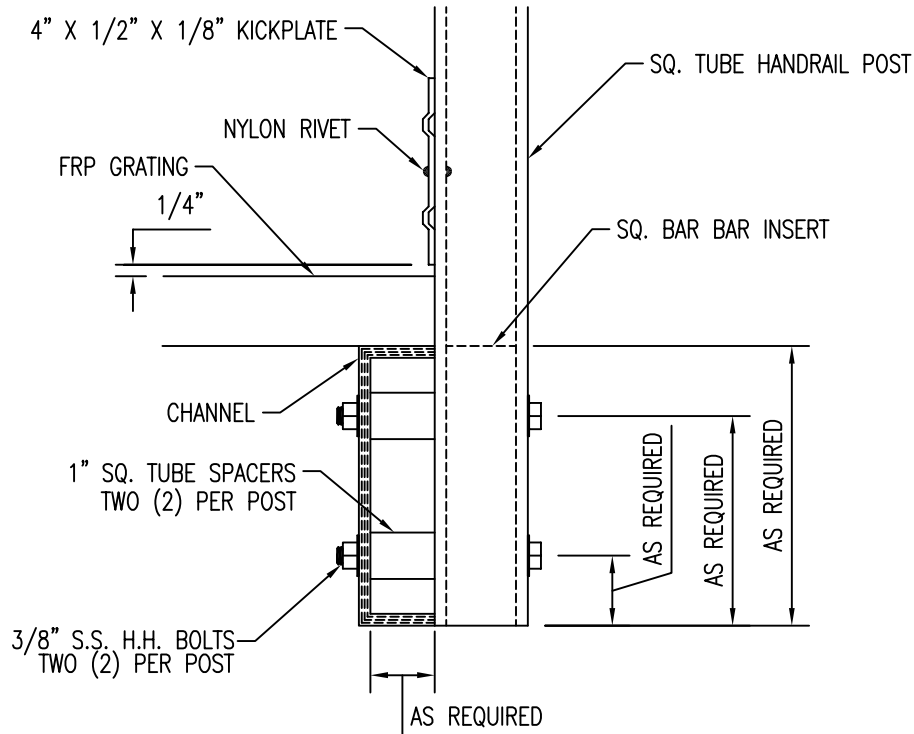

HANDRAIL TO CHANNEL CONNECTIONS



264 REYNOLDSDALE ROAD
BEDFORD, PENNSYLVANIA 15522

PHONE: 814-623-8125 WEB SITE: www.bedfordreinforced.com
FAX: 814-623-6032 EMAIL: sales@bedfordreinforced.com

TITLE:

STANDARD
AND HEAVY DUTY
HANDRAIL
TO CHANNEL CONNECTIONS

HANDRAIL TYPE:
FR RESIN:
VE RESIN:

HANDRAIL COLOR:
YELLOW:
OTHER: _____
(IF OTHER PLEASE NOTE COLOR)

SCALE: N.T.S.

DATE: 5-15-14

DRAWN BY: BB

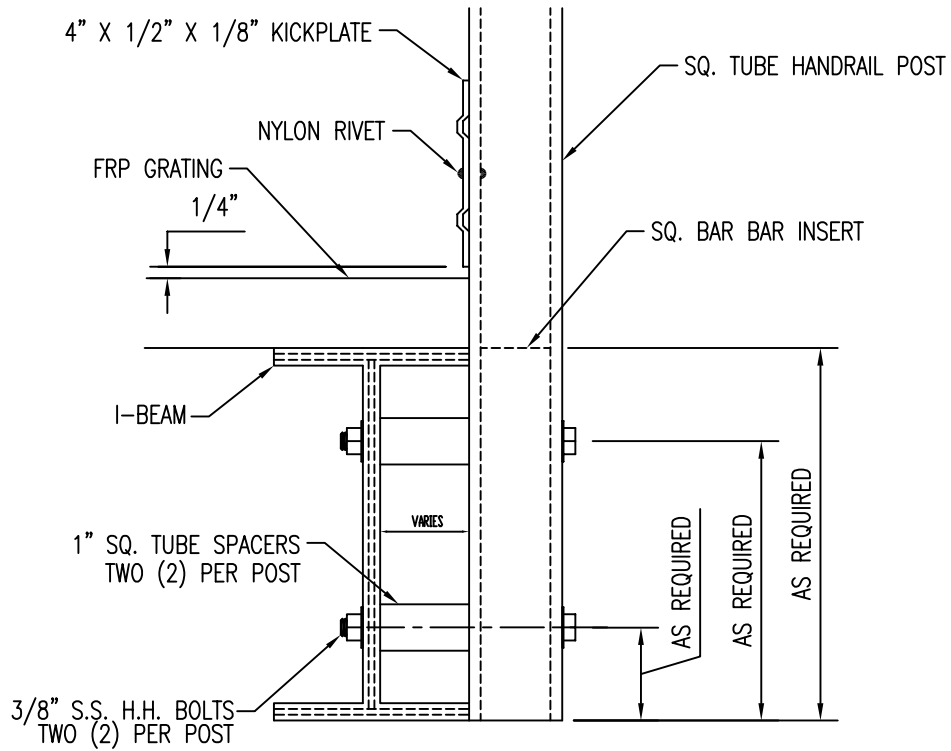

HANDRAIL TO I-BEAM CONNECTIONS



264 REYNOLDSDALE ROAD
BEDFORD, PENNSYLVANIA 15522

PHONE: 814-623-8125 WEB SITE: www.bedfordreinforced.com
FAX: 814-623-6032 EMAIL: sales@bedfordreinforced.com

TITLE:

STANDARD
AND HEAVY DUTY
HANDRAIL
TO I-BEAM
CONNECTIONS

HANDRAIL TYPE:
FR RESIN:
VE RESIN:

HANDRAIL COLOR:
YELLOW:
OTHER: _____
(IF OTHER PLEASE NOTE COLOR)

SCALE: N.T.S.

DATE: 5-15-14

DRAWN BY: BB

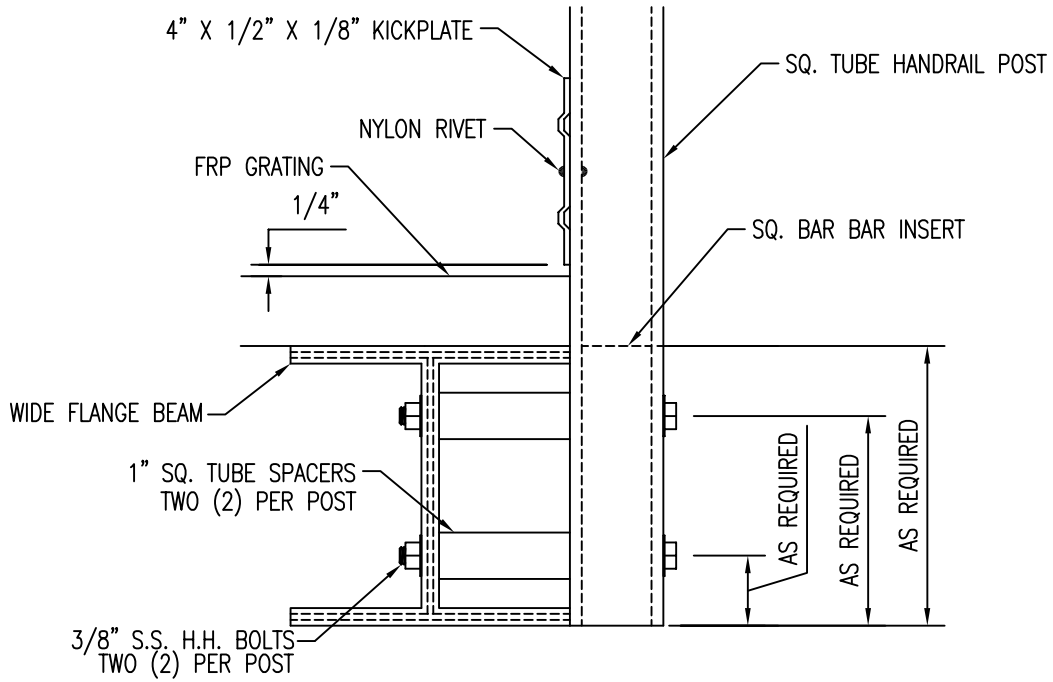

HANDRAIL TO WIDE FLANGE BEAM CONNECTIONS



264 REYNOLDSDALE ROAD
BEDFORD, PENNSYLVANIA 15522

PHONE: 814-623-8125 WEB SITE: www.bedfordreinforced.com
FAX: 814-623-6032 EMAIL: sales@bedfordreinforced.com

TITLE:

STANDARD
AND HEAVY DUTY
HANDRAIL
TO WIDE FLANGE BEAM
CONNECTIONS

HANDRAIL TYPE:
FR RESIN:
VE RESIN:

HANDRAIL COLOR:
YELLOW:
OTHER: _____
(IF OTHER PLEASE NOTE COLOR)

SCALE: N.T.S.

DATE: 5-15-14

DRAWN BY: BB

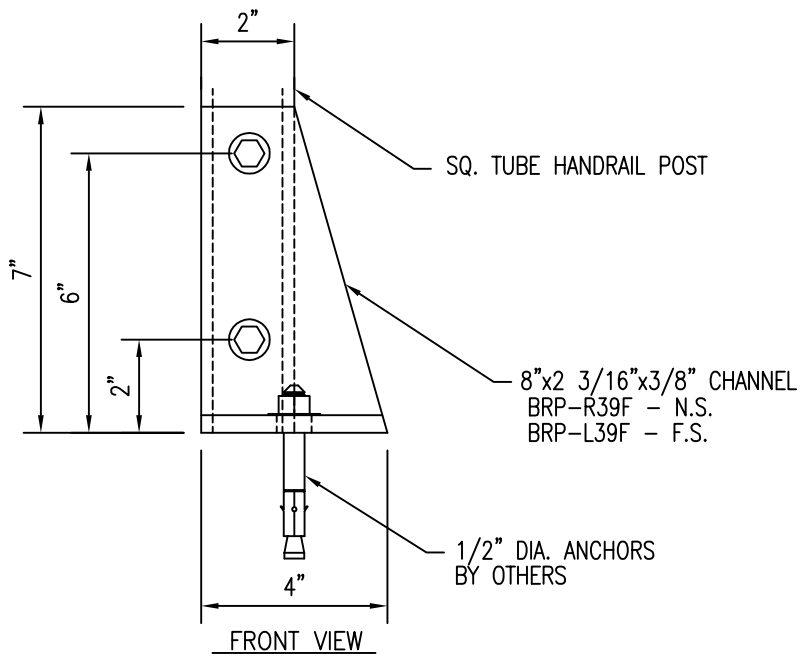
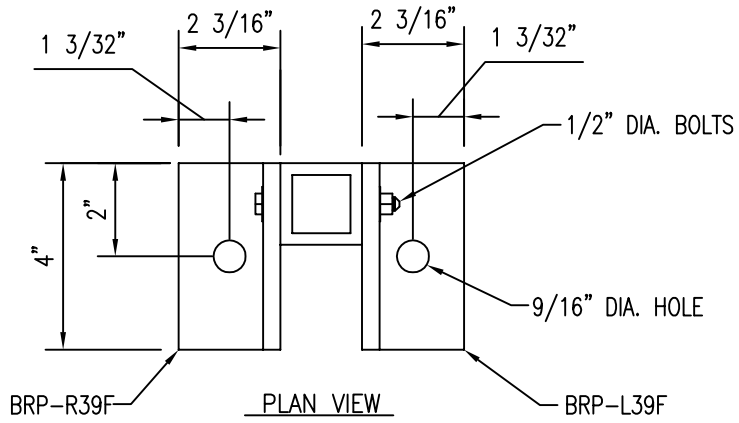

BASEPLATE MOUNTED HANDRAIL



264 REYNOLDSDALE ROAD
BEDFORD, PENNSYLVANIA 15522

PHONE: 814-623-8125 WEB SITE: www.bedfordreinforced.com
FAX: 814-623-6032 EMAIL: sales@bedfordreinforced.com

TITLE:

STANDARD
AND HEAVY DUTY
HANDRAIL
BASE PLATE MOUNT

HANDRAIL TYPE:
FR RESIN: DK. GRAY
VE RESIN: BEIGE

SCALE: N.T.S.

DATE: 5-15-14

DRAWN BY: BB

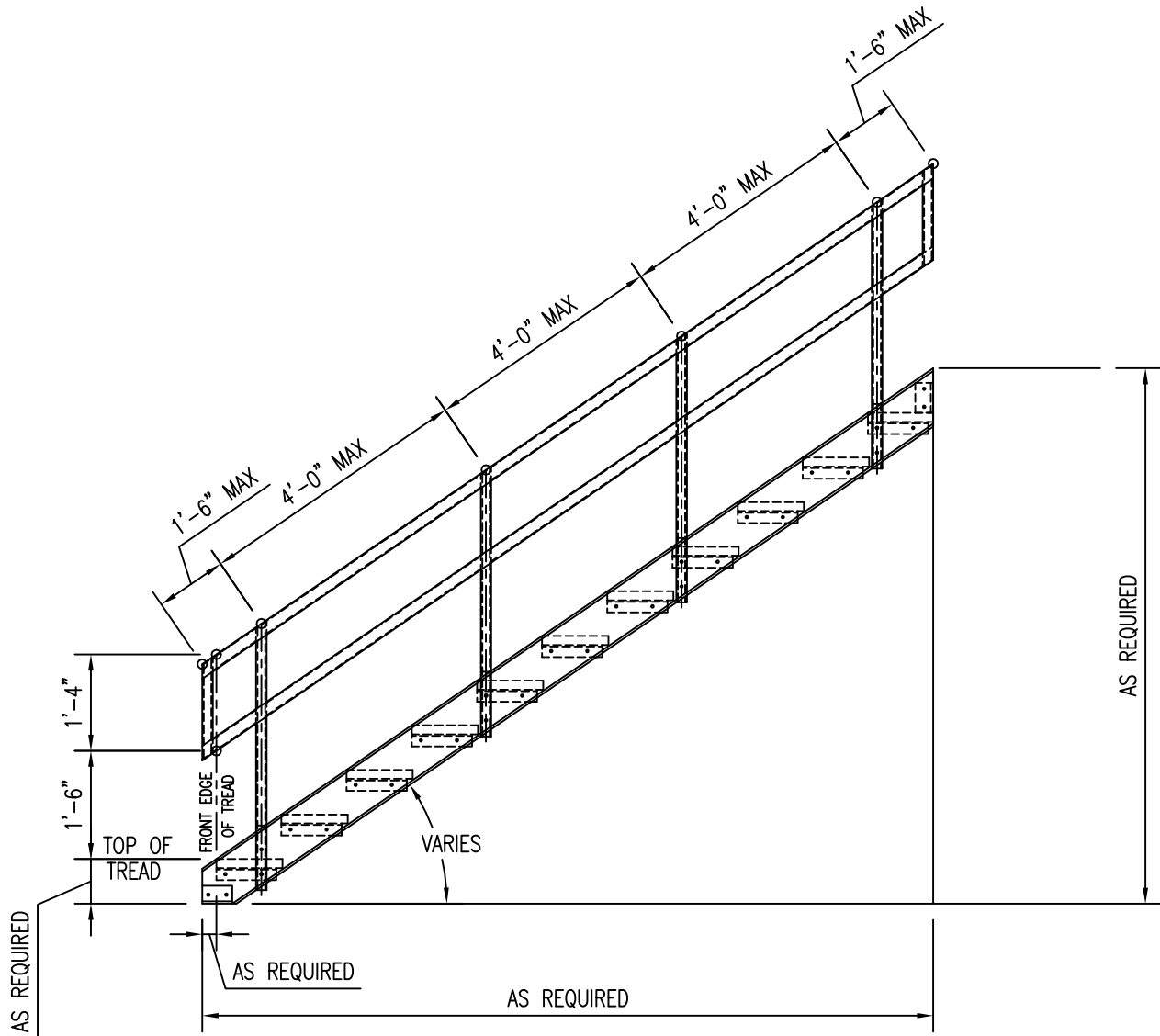

STANDARD AND HEAVY DUTY STAIR HANDRAIL (OSHA SPEC)



264 REYNOLDSDALE ROAD
BEDFORD, PENNSYLVANIA 15522

PHONE: 814-623-8125 WEB SITE: www.bedfordreinforced.com
FAX: 814-623-6032 EMAIL: sales@bedfordreinforced.com

TITLE:

STANDARD
AND HEAVY DUTY
STAIR HANDRAIL
OSHA SPEC

HANDRAIL TYPE:
FR RESIN:
VE RESIN:

HANDRAIL COLOR:
YELLOW:
OTHER: _____
(IF OTHER PLEASE NOTE COLOR)

SCALE: N.T.S.

DATE: 5-15-14

DRAWN BY: BB